

# 663 NIGHT LIFE INSTRUCTIONS

Follow these step-by-step instructions to construct the Night Life's Belvidere Theatre, Bottoms Up Bar and Grill and The Blue Note. Refer to Walls 1-4, in Step 3 and walls 7-10 in step 4 to identify each building part and determine its proper location.

## 663 BUILDINGS PARTS LIST

### Bottoms Up

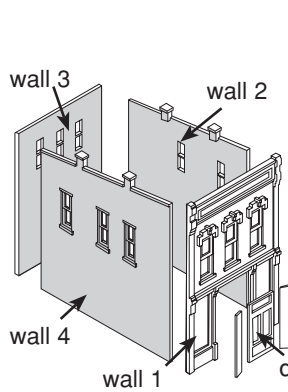

### The Blue Note

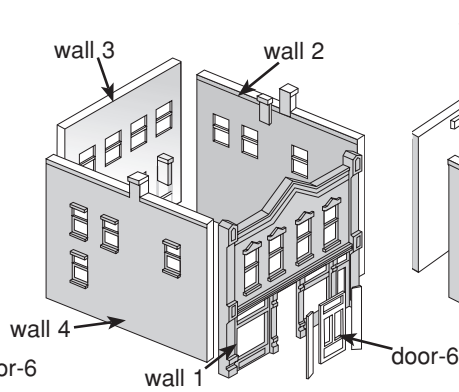

### The Belvidere Theatre

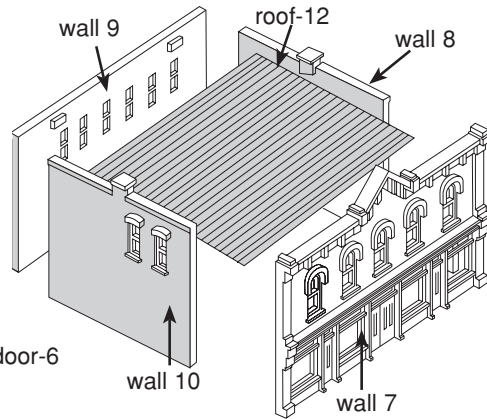

Bottoms Up & Blue Note are constructed in a similar manner so their instructions have been combined (steps 2 and 3)

#### Additional Material -

Styrene roof material-1 (3.5" x 3.5")  
Clear window material-1 (5" x 5")  
Wire for canopy supports-6"

Styrene stick (roof supports)-2 (4.06" x .08")  
Styrene strip (door side panels)-2 (.156" x 2" x .02")  
Black paper-1 (7 3/4" x 4 1/2")  
Styrene (carpet material)-1 (4" x 1" x .005")

Dry transfer decal sheet-1  
Pepsi Billboards, poster & sign board sheets-1  
Marquee sign sheet-1  
See end panel for White Metal Castings listing.

## 1 Prepare all parts. Sand specified edges.

Use a hobby knife or diagonal cutters (i.e. Fiskars) to remove excess plastic created by molding process. Do not cut into detail or mix parts for buildings. Follow instructions to remove draft angles from edges of all the molded parts.

Note: This step is essential to achieve proper fit later. Be careful to never sand into details of buildings.

Tack 100 grit sandpaper to flat surface. Make sanding area longer than the longest wall of the models. Using squaring block, keep edges flat and hold panels square as you sand. Move wall panel, not the block. See illustration in Steps 3 and 4 for wall edges to sand.

Lightly sand or file the smooth sides and bottom of chimneys to remove draft angles.

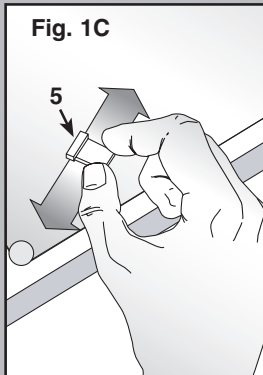
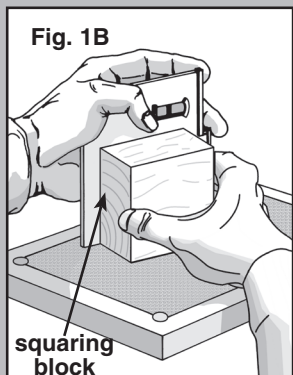
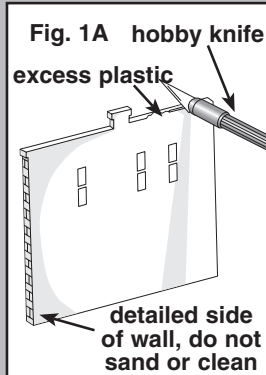

## 2 Glue chimney backs and assemble doorways.

Although different in appearance, Bottoms Up and Blue Note are constructed in a similar manner. Because of this, their instructions have been combined.

Glue chimney backs to molded-in chimney front on walls (Fig. 2A). When glue is dry, sand tops of chimneys flat.

Assemble doorways for Bottoms Up and Blue Note.

Cut two entry door side panels from the narrow white styrene strip for each building. Make them the same height as the entry door castings. Glue side panels to entry doors as shown in Fig. 2B. Now glue fronts of entry door side panels to back of entry opening on building front. (Fig. 2C).

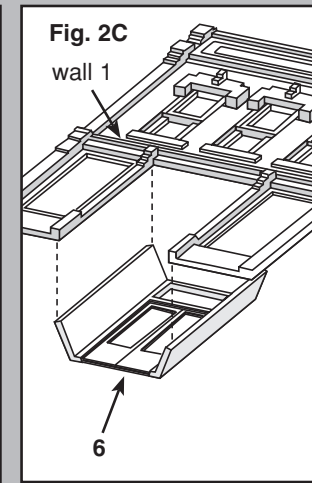
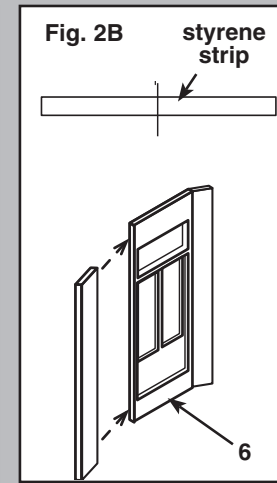
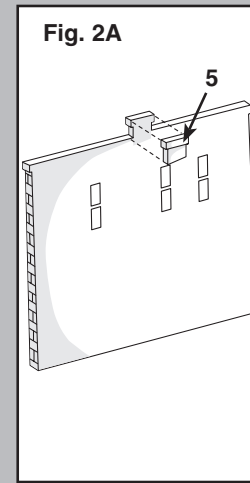

## 3 Assemble walls and roofs for Bottoms Up and Blue Note.

Glue front wall (1) to both side walls (2 & 4). Try to match the brick courses at the glue joint while keeping the bottoms of the walls flush.

Make sure the walls are square to each other. Use a block of wood to square them if necessary. Test fit the rear wall between the side walls. Glue back wall to side walls when satisfied with fit.

Assemble roofs for Bottoms Up and Blue Note.

Make a template by tracing inside roof opening on scrap cardboard. Cut out and test fit the cardboard square on top of the buildings. Adjust as needed.

Trace cardboard roof on styrene square provided and cut out roof (Fig. 3B).

Slide roof through bottom of model and glue to underside of chimneys (Fig. 3C).

Cut styrene sticks to make roof supports and glue into place under styrene roof (Fig. 3C).

Paint and Detail.

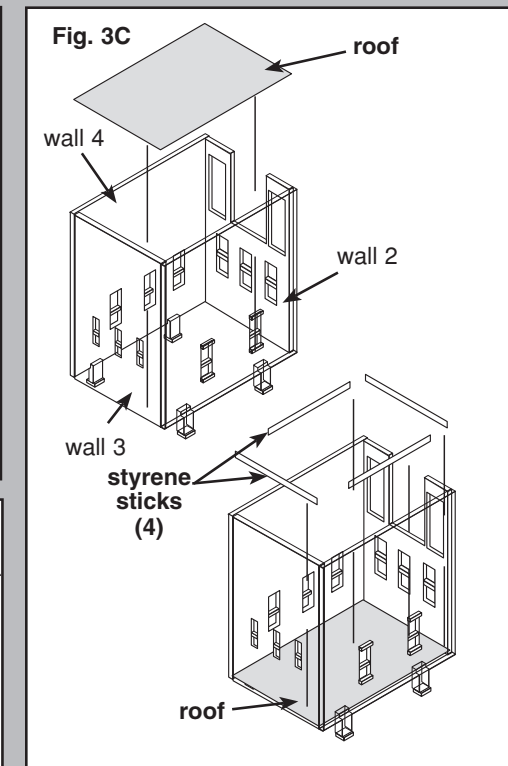
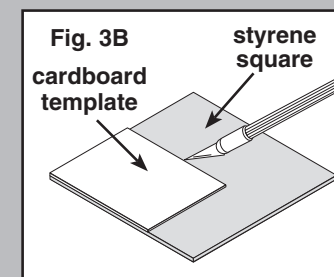
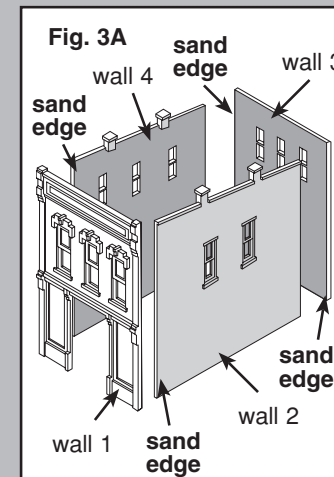

## 4 Assemble walls and roof for Belvidere Theatre.

Note: The Belvidere Theatre is the only model that has walls with molded-in alignment pins.

Butt rear wall 9 against side alignment pins of side walls 8 and 10 (Fig. 4A). Check seams to assure perfect fit. Temporarily use roof to square side and rear walls. Glue walls at seams and allow to dry. Front wall will be attached later.

### Assemble roof of Belvidere Theatre.

The roof for The Belvidere Theatre must be installed before placing the front wall.

Roof may be placed with rolled roofing side up or smooth side up, according to your preference. Install roof by sliding it in from the front. Roof will slope slightly to rear of building. Note that rolled roofing edge must slope toward rear in step fashion (Fig. 4B). Rear of roof rests on rear wall's alignment pins and butts to underside of chimneys. Apply glue to roof from underside of building. Allow to dry.

### Assemble front wall of Belvidere Theatre.

After glue has thoroughly dried, tip building on its face and lightly sand in a circular motion (Fig. 4C). Trial fit front wall to rest of building, check seams for gaps. To remove gaps, repeat sanding step. When fit is snug, apply glue to seams inside building.

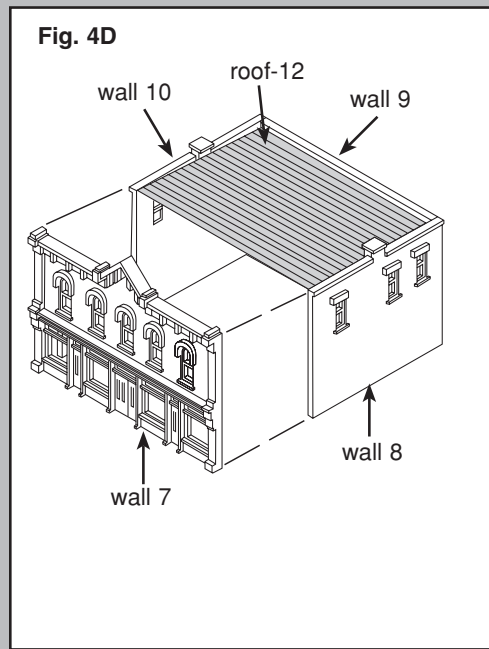
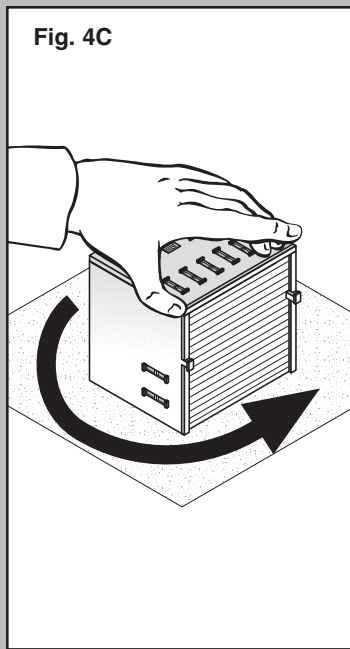
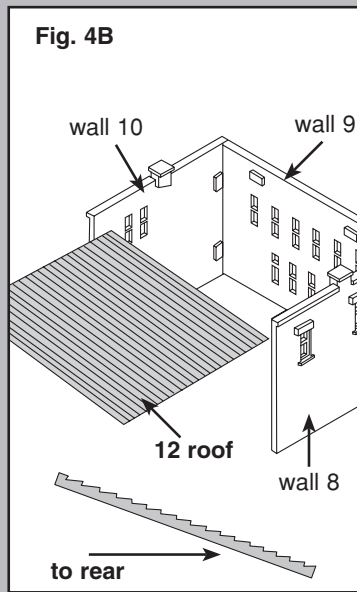
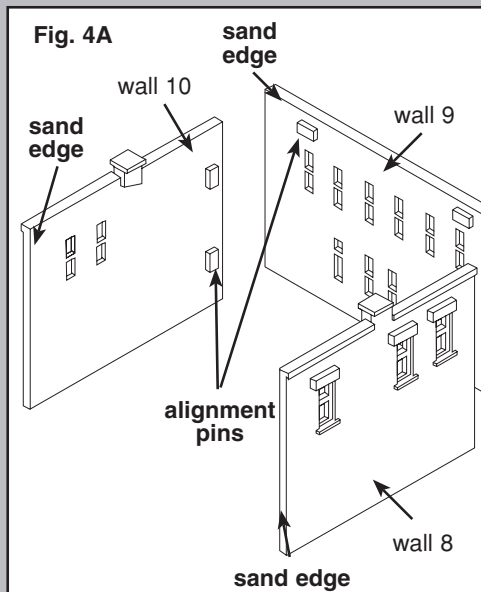

### Preparing white metal castings.

Remove parting lines, flash and stems with a hobby knife (i.e., X-Acto), diagonal cutters (i.e., Fiskars), sandpaper or file. Align and fit castings. Note: Castings bend easily and should be handled carefully. Straighten bent or warped castings.

Wash all metal castings in soapy water to remove residue caused by molding process. Rinse and allow parts to dry.

Plan ahead; it is often easier to paint certain castings before assembly. We recommend using a primer coat and then painting castings with a high quality, flat paint. If you paint, scrape paint from glue points before gluing and touch up paint if necessary after assembly. See PAINTING under FINISHING TOUCHES for some helpful hints. Glue castings together with a fast-setting epoxy or a cyanoacrylate such as "super glue." (A thick, gap-filling cyanoacrylate is recommended.)

### DETAILS PARTS LIST

The following list contains all details included with the 663 kit. Sort and organize individual detail parts; this will make assembly easier.

	Part No.	Name	Qty.		Part No.	Name	Qty.
<b>WINDOW ENCLOSURES</b>	1	Board covering (side a)		<b>SWAMP COOLER</b>	25	Side .....	4
		Brick covering (side b) .....	15		26	Top.....	1
<b>CANOPY &amp; AWNINGS</b>	2	Canopy Support .....	1	<b>NEWSSTAND</b>	27	Roof.....	1
	3	Belvidere Sidewalk Canopy (Plastic) .....	1		28	Walls.....	1
	4	Belvidere Canopy Wire Post.....	2	<b>ROOFTOP BILLBOARD</b>	29	Rooftop Billboard.....	1
	5	Belvidere Window Awnings (Plastic) .....	5		30	Billboard Brackets .....	3
	6	Bottoms Up Awning (Plastic).....	1	<b>SEARCHLIGHT</b>	31	Generator .....	1
	7	Awnings for Blue Note .....	4		32	Main Frame Deck with Fenders.....	1
	8	Backdoor Awning (Blue Note) .....	1		33	Axles.....	2
<b>SIGNS &amp; MARQUEES</b>	9	Marquees .....	2		34	Wheels .....	4
	10	"Belvidere Theatre" Sign.....	1		35	Battery Box.....	1
	11	Beer Bottle .....	1		36	Wheel Jack.....	1
	12	Blue Note Sign .....	1		37	Tool Box .....	1
	13	Small Sidewalk Sign Board.....	1		38	Tail Light Bar .....	1
	14	Sign Board (Evelyn West).....	1		39	Exhaust Stack .....	1
	15	Movie Poster (Paper) .....	9		40	Searchlight .....	1
	16	Marquee Signs (Paper) .....	2		41	Pivot Yoke .....	1
<b>BUILDING DETAILS</b>	17	Roof Hatch .....	2		42	Control Box .....	1
	18	Trap Door (Blue Note).....	1	<b>MISC. DETAILS</b>	43	Light Post .....	4
	19	Large Roof Vents .....	6		44	City Sidewalk Bench .....	2
	20	Small Roof Vents.....	6		45	Maildrop Box .....	1
	21	Down Spouts.....	2		46	Dog.....	1
	22	Power Meter.....	3		47	Keg Grouping.....	1
	23	Building Lights.....	3		48	Pallets.....	3
	24	Curtains (paper) .....	2		49	Garbage Cans.....	6
					50	Single Barrel.....	1
					51	Sidewalk Garbage Can .....	2
					52	Fire Hydrants.....	2
					53	Propane Tank .....	1
					54	Barrel Grouping.....	1

## Paint building.

We recommend that you paint all building parts for the most realistic appearance.

See Painting under Finishing Touches for helpful hints.

NOTE: When attaching details to building, clean paint from surfaces to be glued. Touch up paint if needed.

## 5 Prepare and install window enclosures.

Part 1, window enclosure, is reversible. Side (a) shows brick, side (b) shows wood. Fig. 5B shows suggested placement, but either option is available.

To prepare a window enclosure for the particular window you are covering, cut metal casting from sprue and sand to fit width and height of opening. Sand to remove excess material. Test fit and make final adjustments; glue in place on side and back walls.

Repeat with other window enclosures (Fig. 5B). The windows in the Belvidere Theatre vary in size so check each opening before sanding.

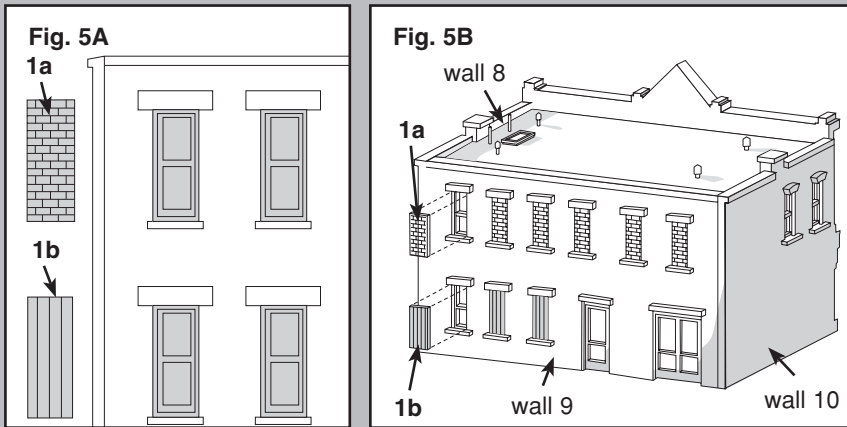

## 6 Install window material on all three buildings.

Only the window openings on walls 1 and 7 and windows on doors will have clear window material.

Window openings can be covered a floor at a time. Measure each floor's window openings and cut clear window material to fit (Fig. 6). Important Note: Dry Transfer Decals are applied face up to outside of window material before window material is installed. See DRY TRANSFER DECALS to apply.

Then carefully glue window material to inside of window openings.

Repeat for each set of window openings on all buildings.

If you wish to install posters in windows on first floor of Belvidere Theatre, select the ones you wish to use, carefully cut them out (do not remove black frame around poster), and test fit on window material. Use clear tape or glue to attach them to the back side of window material.

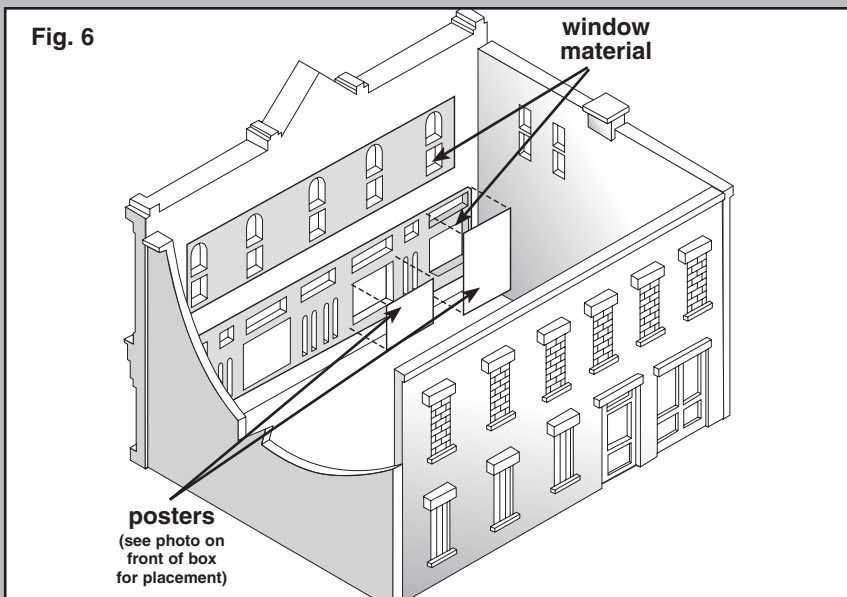

## 7 Paint, apply decals and cut awnings and canopies.

Paint Awnings and Canopies the color of your choice and let them dry. Apply appropriate Dry Transfer Decals before cutting Awnings and Canopies from sheet. (Consult picture on the box to determine the Dry Transfer Decal set for Awnings and Canopies. Follow instructions for Dry Transfer Decals under Finishing Touches section.)

### Cut out canopies and awnings

Cut carefully around Parts 3, 5, 6 and 7 using a sharp hobby knife.

Remove backsides or bottoms of Parts 3, 5, 6 and 7. Cut off sides to molded-in line of Part 6, so it will fit wall at right angle.

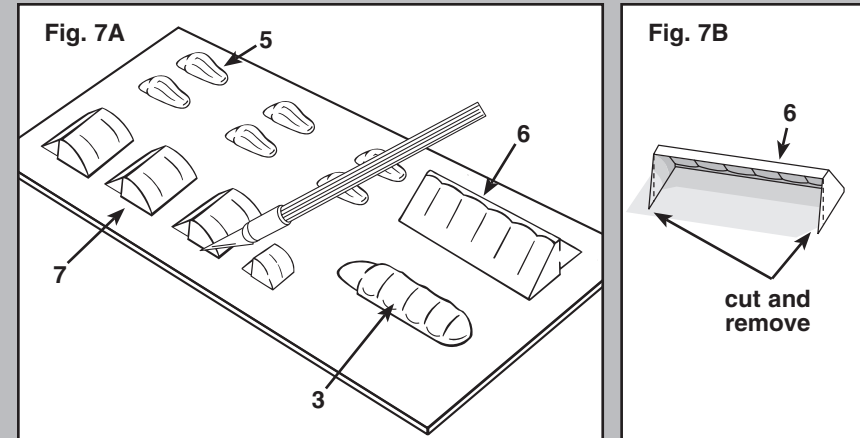

## 8 Install canopies, marquees, awnings and signs.

Paint remaining castings. Apply decals where appropriate. See photo on box.

Glue Parts 2 through 7 and Parts 9 to buildings as shown in Fig. 8A.

Cut a 2-7/8" x 5/16" strip of carpet from styrene material. Cut a second strip 1/2" x 1/4". Paint carpet and glue down in front of Belvidere Theatre after model is positioned on layout. (Fig. 8A)

Cut blue paper Curtains from sheet to fit bottom windows of Blue Note. Use a small square of tape to hold them in place.

Cut and sand "foot" on lower bracket of Part 10, Belvidere Sign, to fit Wall 7 as shown in Fig. 8A.

Attach Parts 10 through 12 to buildings as shown on box.

Glue Parts 7 to building as shown in Fig. 8B.

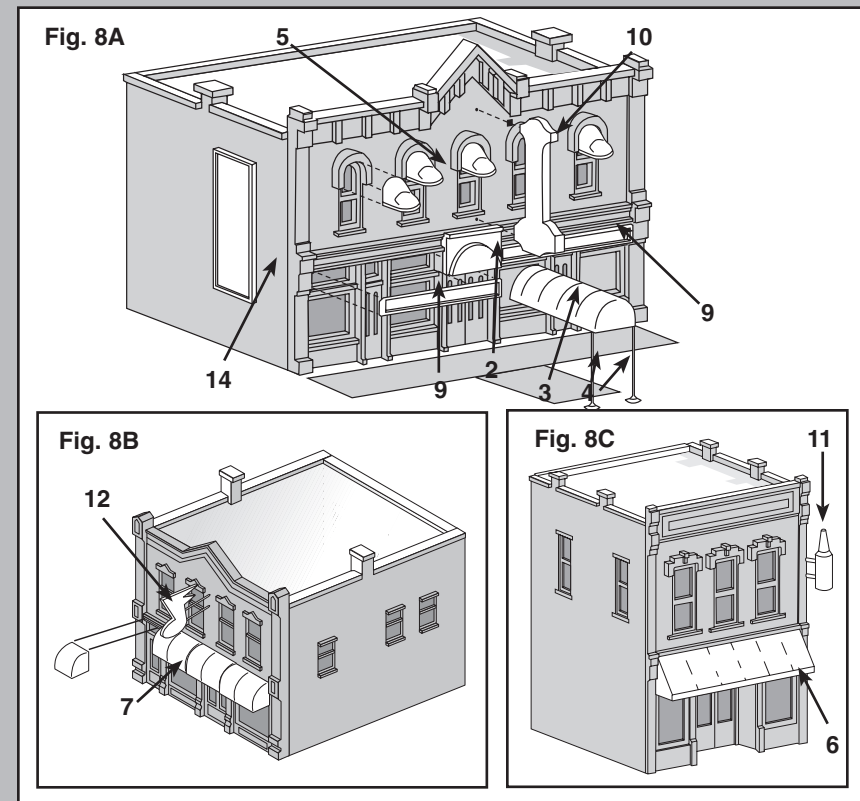

## 9 Finish installing details.

Glue Parts 8 and 17-23 to buildings where shown on the box and in Fig. 9A, 9B and 9C or where desired.

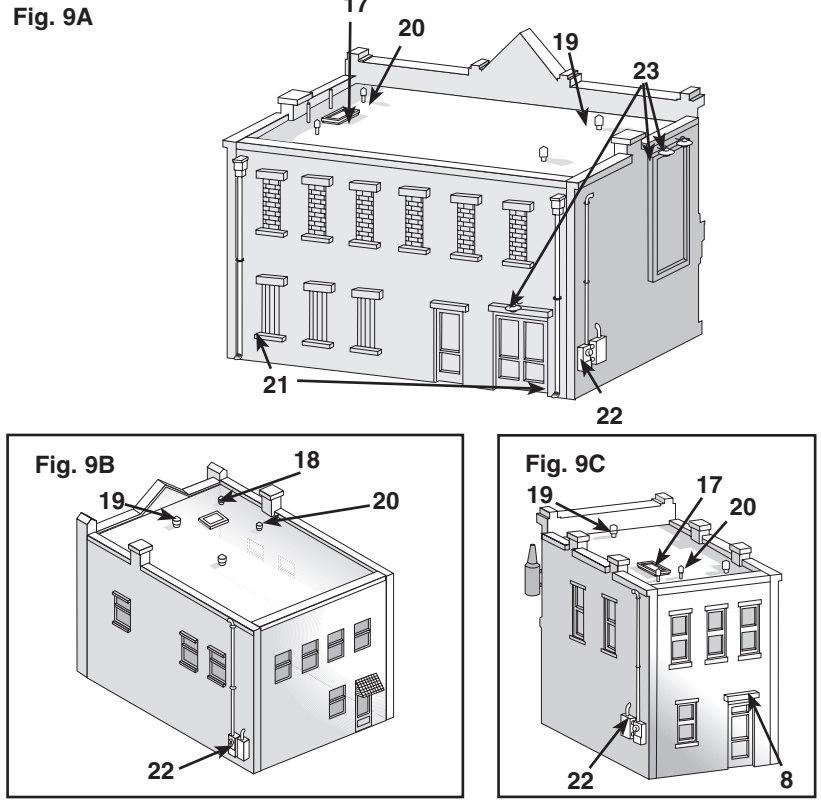

## 10 Assemble swamp cooler, newsstand and billboard.

Glue the four Parts 25 together (Fig. 10A.) Glue Part 26 to assembled Parts 25. Place on building roof where desired.

Assemble parts 27-28 as shown.

Assemble parts 29-30 as shown. Cut out picture of your choice from selection to fit Billboard. Spread a small drop of white glue evenly over the back of picture and place in Billboard face.

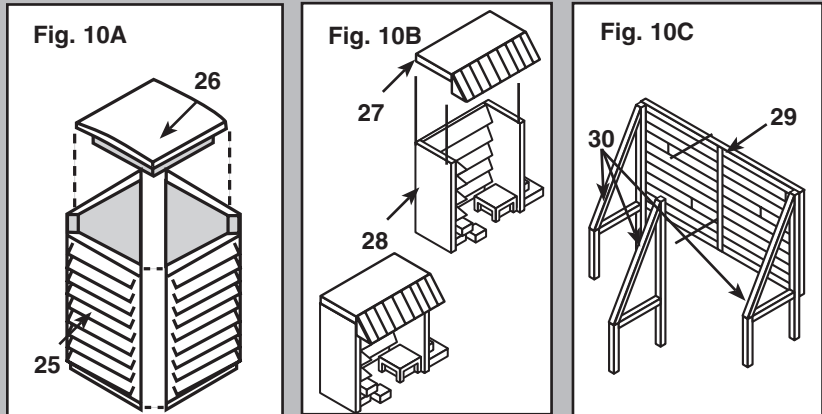

## 11 Assemble searchlight.

Glue parts 31-42 in place and allow to dry (see Figs. 11A, 11B and 11D).

Optional: If desired, use pattern in 11C to carefully cut a lens for spotlight out of clear window material. Smooth edges with fine sandpaper and snap in place. Place finished spotlight where desired.

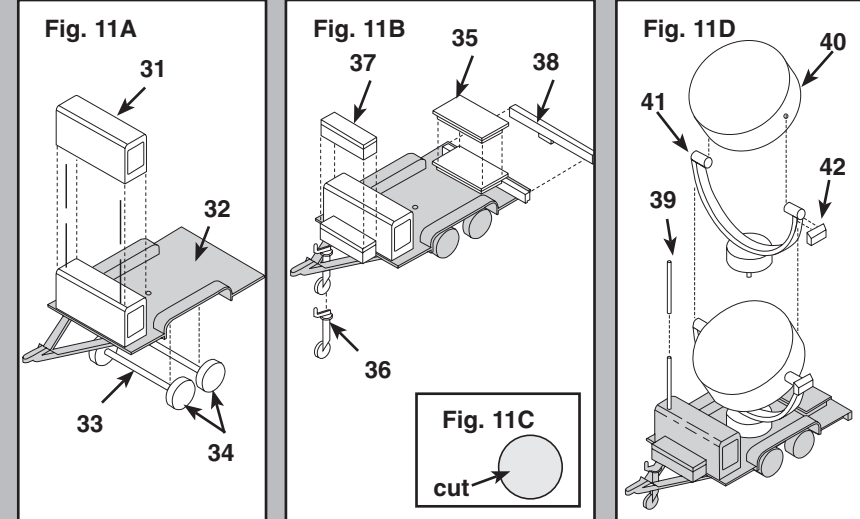

## FINISHING TOUCHES

### PAINTING

We recommend airbrushing with solvent-based enamel paints, such as Floquil, in a flat finish. Use water soluble flat paint such as Polly 'S' for brushing (color is your choice). We prefer natural brick colors in earth tones for the buildings. Other suggestions: roofs - "Flat Black," vents - a black or gray color. Color of window and door frames can match or contrast with building. Building may be aged with chalks or lightly misted by airbrushing with thinned flat black paint such as Floquil 'Grimy Black.' Small details painted a contrasting color will enhance the building's appearance. See the picture on the box for painting ideas. Scrape paint from glue points as necessary.

### OPTIONAL IDEA

To complete the illusion that buildings are occupied, place black paper (included in this kit) diagonally from corner to corner inside buildings to block light from entering. You may want to apply a very fine sand to the roofs to simulate a "gravel" texture.

### DRY TRANSFER DECALS

**NOTE:** If decals are fragmented they can still be used, this adds a realistic, weathered look.

- Place dry transfer decals in position shown on front of package, or where desired.
- Hold carrier sheet gently so it cannot move while you rub over the decal with a burnisher or dull pencil.
- Carefully remove carrier sheet. If transfer was incomplete, let sheet fall back into place and transfer remainder.
- Place backing paper over decal and reburnish. Repeat with other decals.

**NOTE:** The cast details and Dry Transfers in this kit were made by Woodland Scenics for Design Preservation Models. See the entire line of Woodland Scenics Dry Transfers and castings at your favorite hobby store.

Look through the enclosed catalog to see the complete line of DPM N scale buildings.

Design Preservation Models

P.O. Box 66  
Linn Creek, MO 65052

MADE IN USA

© 1999 DPM